

IMPORTANT – READ CAREFULLY – RETAIN FOR FUTURE REFERENCE

WICHTIG – SORGFÄLTIG LESEN UND AUFBEWAHREN

H/95

1

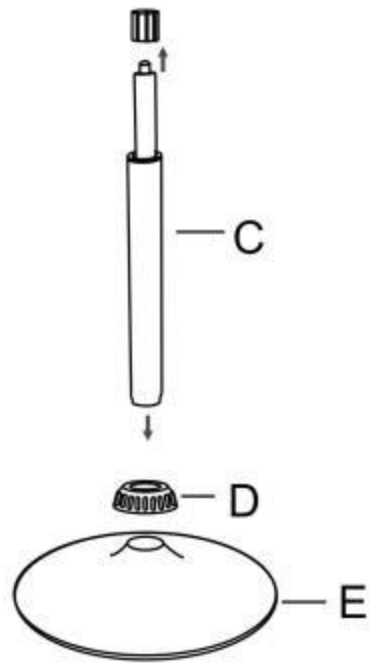

2

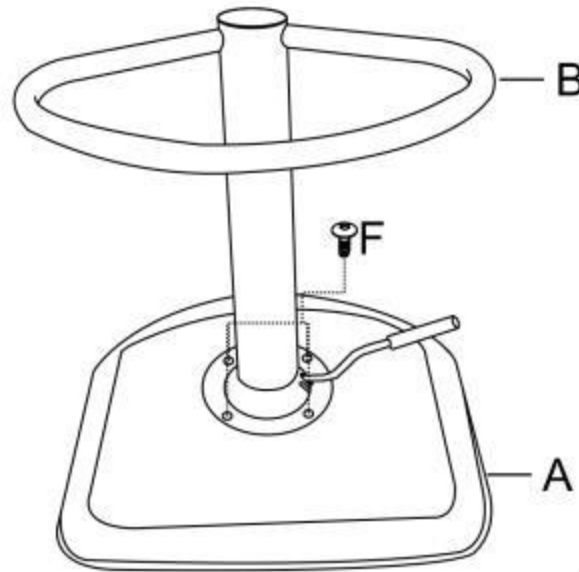

3

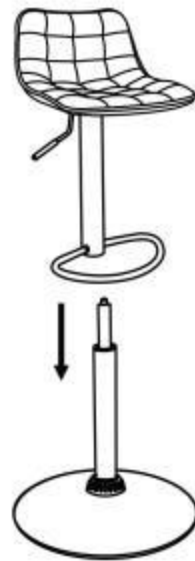

4

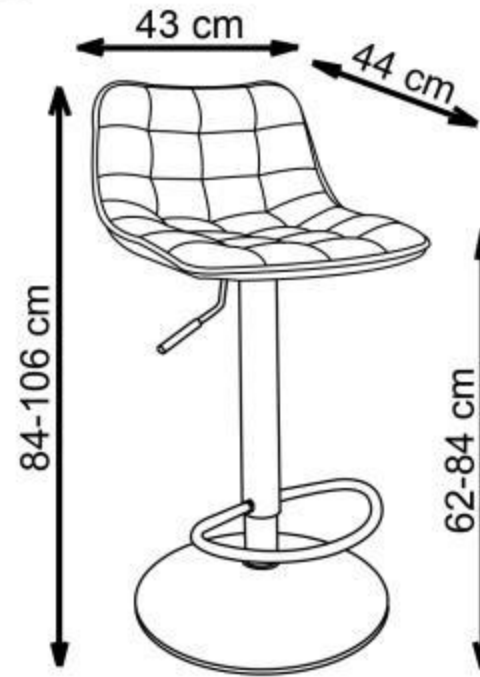

A		1
B		1
C		1
D		1
E		1
F		4

max. 100kg