

IMPORTANT – READ CAREFULLY – RETAIN FOR FUTURE REFERENCE

WICHTIG – SORGFÄLTIG LESEN UND AUFBEWAHREN

FREGATA

1

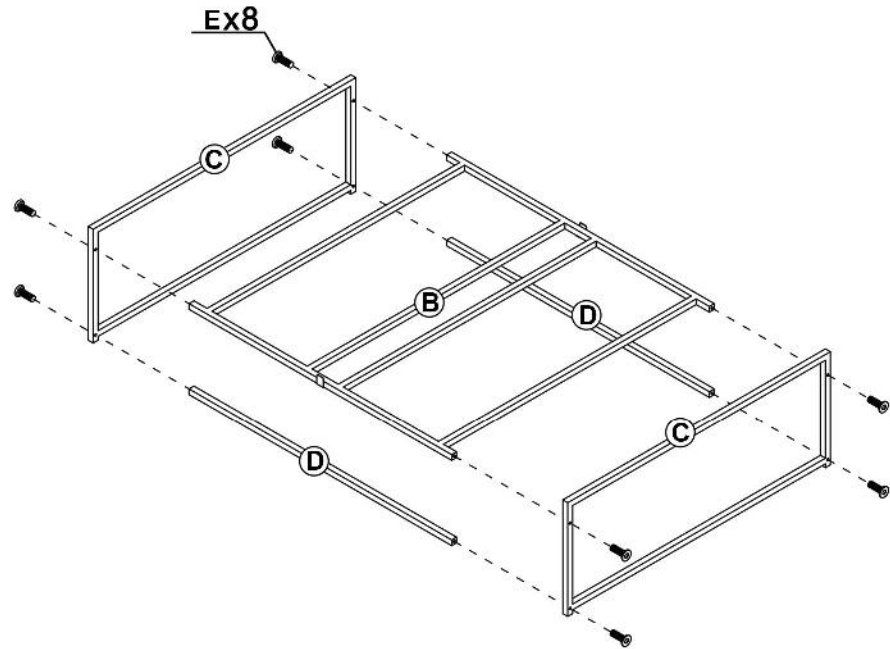

2

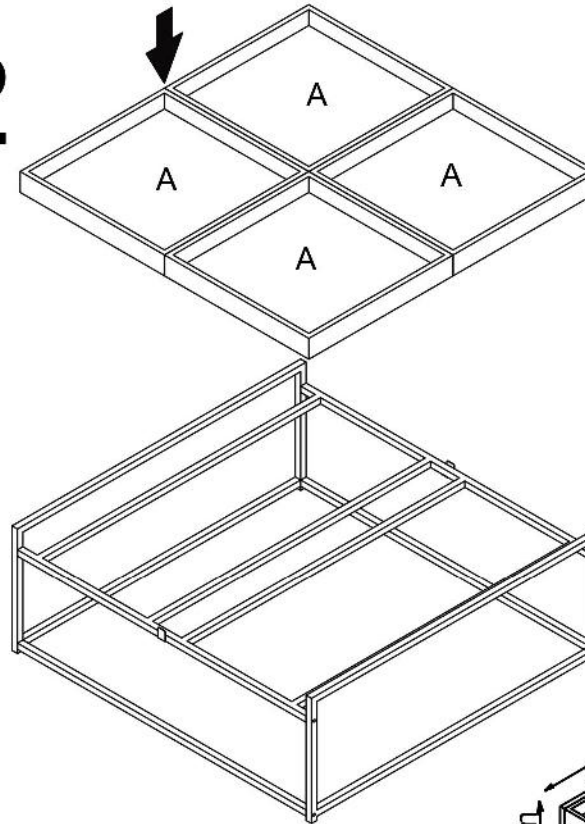

| | | |
|---|------------|---|
| A | | 4 |
| B | | 1 |
| C | | 2 |
| D | | 2 |
| E | 6x35mm | 8 |

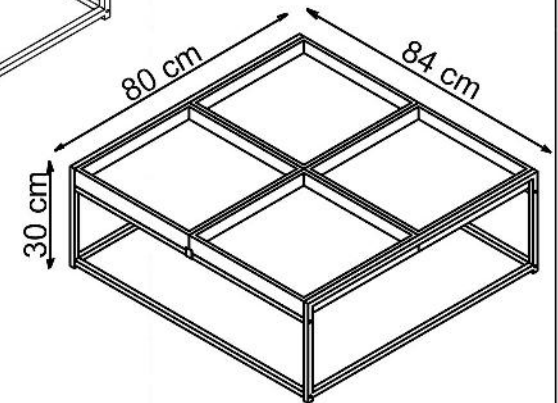

max. 20 kg



v.1